

DPP – 3 (Capacitor)

Video Solution on Website:-

<https://physicsaholics.com/home/courseDetails/65>

Video Solution on YouTube:-

<https://youtu.be/fIS61xdB8vw>

Written Solution on Website:-

<https://physicsaholics.com/note/notesDetails/62>

Q 1. Calculate the reading of voltmeter between X and Y then $(V_x - V_y)$ is equal to -

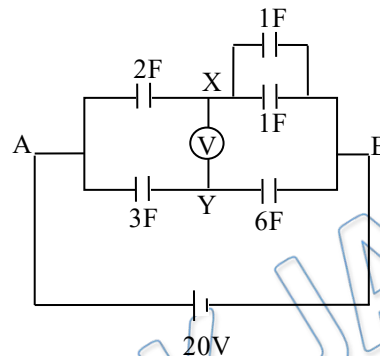

- (a) 10 V (b) 13.33V (c) 3.33 V (d) 10.33 V

Q 2. Three capacitors of capacitors C_1 , C_2 , C_3 are connected as shown in the figure. The points A, B and C are at potential V_1 , V_2 and V_3 respectively. Then the potential at O will be -

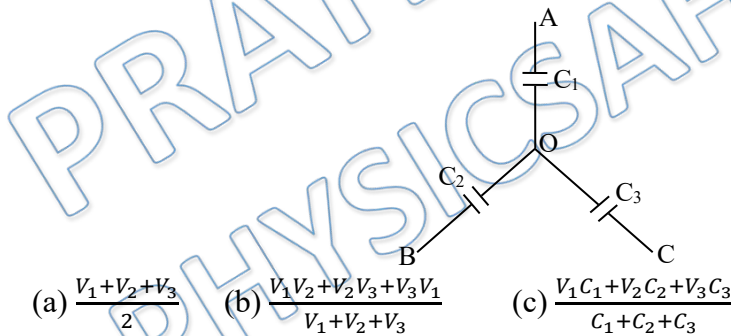

- (a) $\frac{V_1+V_2+V_3}{2}$ (b) $\frac{V_1V_2+V_2V_3+V_3V_1}{V_1+V_2+V_3}$ (c) $\frac{V_1C_1+V_2C_2+V_3C_3}{C_1+C_2+C_3}$ (d) zero

Q 3. A circuit has a section AB shown in the figure. The emf of the source equals $e = 10V$, the capacitance as of the capacitors are equal to $C_1 = 1.0 \text{ mF}$ and $C_2 = 2.0 \text{ mF}$, the potential difference $f_A - f_B = 5.0V$. The voltage across capacitor C_1 & C_2 is respectively :

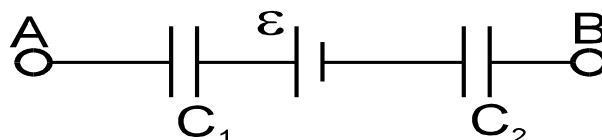

- (a) $10/3 \text{ V}$, $5/3 \text{ V}$ (b) $10/3 \text{ V}$, $10/3 \text{ V}$
 (c) $5/3 \text{ V}$, $5/3 \text{ V}$ (d) 0 V , 0 V



- Q 4. $2\mu\text{F}$ capacitance has P.D across its two terminals of 200 V. It is disconnected from the battery and when another uncharged capacitor is connected in parallel to it, P.D becomes 20 V. The capacity of another capacitor will be:
- (a) $2\mu\text{F}$ (b) $4\mu\text{F}$
(c) $18\mu\text{F}$ (d) $16\mu\text{F}$
- Q 5. A capacitor of $10\mu\text{F}$ charged upto 250 V is connected in parallel with another capacitor of $5\mu\text{F}$ charged upto 100 V (plates of like charges connected together). The common potential is :
- (a) 200 V (b) 300 V
(c) 400 V (d) 500 V
- Q 6. A $10\mu\text{F}$ capacitor is charged to a potential difference of 1000V. The terminals of the charged capacitor are disconnected from the power supply and connected to the terminals of an uncharged $6\mu\text{F}$ capacitor. What is the final potential difference across each capacitor ?
- (a) 167 V (b) 100 V
(c) 625 V (d) 250 V
- Q 7. A $10\mu\text{F}$ capacitor and a $20\mu\text{F}$ capacitor are connected in series across a 200V supply line. The charged capacitors are then disconnected from the line and reconnected with their positive plates together and negative plates together and no external voltage is applied. what is the potential difference across each capacitor?
- (a) $\frac{400}{9}\text{V}$ (b) $\frac{800}{9}\text{V}$
(c) 400 V (d) 200 V
- Q 8. Three capacitors of capacitance $1\mu\text{F}$, $2\mu\text{F}$ and $3\mu\text{F}$ are connected in series and a potential difference of 11V is applied across the combination. Then, the potential difference across the plates of $1\mu\text{F}$ capacitor is
- (a) 2 V (b) 4 V
(c) 1 V (d) 6 V
- Q 9. The capacitor of capacitance $4\mu\text{F}$ and $6\mu\text{F}$ are connected in series. A potential difference of 500 volts applied to the outer plates of the two capacitor system. Then the charge on each capacitor is numerically
- (a) 6000 C (b) 1200 C
(c) $1200\mu\text{C}$ (d) $6000\mu\text{C}$
- Q 10. Three capacitors of capacitances $3\mu\text{F}$, $6\mu\text{F}$, and $4\mu\text{F}$ are connected as shown across a battery of emf 6V. Find the potential difference and charge on capacitor C_2 .

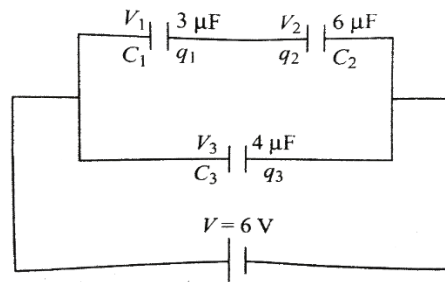

- (a) 2 V, 12 μC (b) 4 V, 12 μC
 (c) 6 V, 36 μC (d) 4 V, 24 μC

Q 11. Three capacitors of capacitances $4\mu\text{F}$, $4\mu\text{F}$, and $8\mu\text{F}$, are connected as shown across a battery of emf 12V. Find the potential difference and charge on capacitor C_2 .

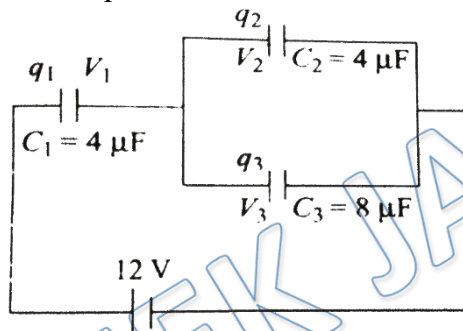

- (a) 3 V, 12 μC (b) 2 V, 8 μC
 (c) 1 V, 4 μC (d) 4 V, 16 μC

Q 12. Two capacitors of capacitance of $6\mu\text{F}$ and $12\mu\text{F}$ are connected in series with a battery. The voltage across the $6\mu\text{F}$ capacitor is 2V. Compute the total battery voltage.

- (a) 2 V (b) 3 V
 (c) 4 V (d) 6 V

Q 13. Two capacitors C_1 and C_2 are charged to 120V and 200V respectively. It is found that connecting them together the potential on each one can be made zero. Then

- (a) $5C_1 = 3C_2$ (b) $3C_1 = 5C_2$
 (c) $3C_1 + 5C_2 = 0$ (d) $9C_1 = 4C_2$

Q 14. A capacitor of $5\mu\text{F}$ is charged to a potential of 100V. Now, this charged capacitor is connected to a battery of 100V with the positive terminal of the battery connected to the negative plate of the capacitor. For the given situation, mark the correct statement.

- (a) The charge flowing through the 100V battery is $500\mu\text{C}$
 (b) The charge flowing through the 100V battery is $1000\mu\text{C}$
 (c) The charge flowing through the 100V battery is $2000\mu\text{C}$
 (d) The charge flowing through the 100V battery is $3000\mu\text{C}$

Q 15. A $1\mu\text{F}$ capacitor and a $2\mu\text{F}$ capacitor are connected in series across a 1200V supply line. The charged capacitors are disconnected from the line and from each other and reconnected with terminals of like sign together. Find the final charge on each and the voltage across them.



- (a) $\frac{1600}{3} \mu\text{C}$, $\frac{3200}{3} \mu\text{C}$, $\frac{1600}{3} \text{V}$ (b) $\frac{1500}{7} \mu\text{C}$, $\frac{3000}{7} \mu\text{C}$, $\frac{1500}{7} \text{V}$
 (c) $\frac{900}{5} \mu\text{C}$, $\frac{1800}{5} \mu\text{C}$, $\frac{900}{5} \text{V}$ (d) $\frac{500}{3} \mu\text{C}$, $\frac{1000}{3} \mu\text{C}$, $\frac{500}{3} \text{V}$

Q 16. If A is connected with C and B is connected with D. How much charge flows in the circuit.



- (a) $12 \mu\text{C}$ (b) $10 \mu\text{C}$
 (c) $8 \mu\text{C}$ (d) $4 \mu\text{C}$

Q 17. In the given circuit, the charge on $4 \mu\text{F}$ capacitor will be :

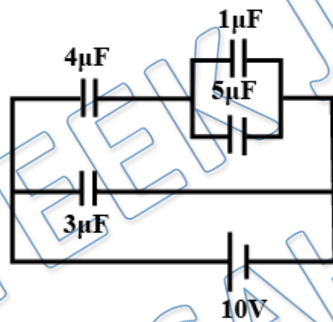

- (a) $5.4 \mu\text{C}$ (b) $24 \mu\text{C}$
 (c) $13.4 \mu\text{C}$ (d) $9.6 \mu\text{C}$



Answer Key

Q.1 c	Q.2 c	Q.3 a	Q.4 c	Q.5 a
Q.6 c	Q.7 b	Q.8 d	Q.9 c	Q.10 a
Q.11 a	Q.12 b	Q.13 b	Q.14 b	Q.15 a
Q.16 a	Q.17 b			

PRATEEK JAIN
PHYSICSAHOLICS